

FLOW-THROUGH FILTERS

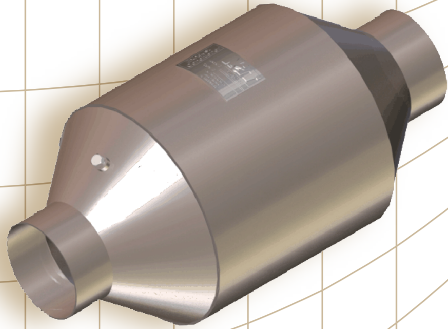

MONOLITH TECHNOLOGY

Flow-through filters (FTF's) utilize a corrugated stainless steel monolith to trap the soot produced by diesel engines. The cylindrical filter substrate allows exhaust gases to flow through the element but heavier particulate matter becomes trapped in its complex structure. The channels in the filter element are large enough to allow exhaust gases and particulates to continue to pass through the filter in the event that the soot storage capacity is reached. In this case, the engine and equipment are able to operate normally, even though the filter is full. This feature allows FTF's to be used on applications producing high particulate emissions such as dirtier, old technology engines.

A proprietary catalyst is coated onto the inside surface of the filter monolith. The catalyst lowers the soot combustion temperature allowing the filter to regenerate. The accumulated soot is oxidized in the filter during regular operation of the engine. Balance point testing shows that FTF's begin PM regeneration at or below 275°C (525°F).

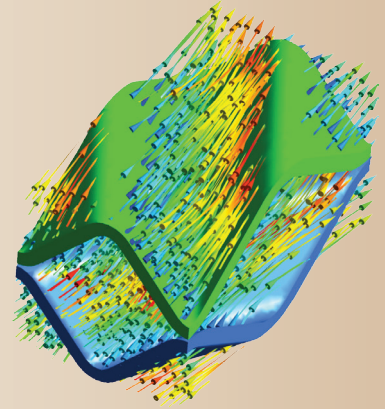

FILTER EFFICIENCY

Due to the presence of the catalyst the FTF achieves high PM and gaseous emissions performance. The soot filtration efficiency of the filter increases with soot accumulation in the unit until it reaches capacity. The visible smoke is greatly reduced and may be completely eliminated by the filter in some applications. Particulates are reduced by 50-70%, carbon monoxide and hydrocarbons by 70-95%.

The catalyzed filter monolith is packaged into a stainless steel housing, which is installed in the vehicle's exhaust system. FTF's are available in direct-fit configurations for hassle-free bolt-on installation on hundreds of applications or universal-fit models suitable for virtually any diesel engine.

Relative Emissions Reductions

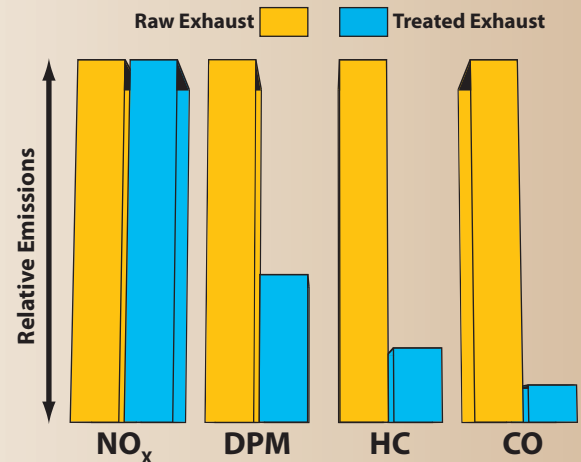

Technical data and information regarding the products described in this brochure is believed to be reliable. However, no representation or warranty is made with respect thereto except as made by Nett[®] Technologies Inc. in writing at the time of sale. © 2010 Nett[®] Technologies Inc.

...the emission control authority.

NETT
NETT TECHNOLOGIES INC.
2-6707 Goreway Drive
Mississauga, ON L4V 1P7 Canada
www.nett.ca
Email: sales@nett.ca
Tel: (905) 672-5453 Fax: (905) 672-5949
Toll-Free (In North America): 1-800-361-6388